

CBSE CLASS X 2007 MATHEMATICS**SET – I (SOLVED)****SECTION - A**

1. If $x + k$ is the GCD of $x^2 - 2x - 15$ and $x^3 + 27$, find the value of k .

Ans.

Let $p(x) = x^2 - 2x - 15$ and $q(x) = x^3 + 27$

Factorising $p(x)$, we get,

$$\begin{aligned} p(x) &= x^2 - 2x - 15 \\ &= x^2 - 5x + 3x - 15 \\ &= x(x - 5) + 3(x - 5) \\ &= (x + 3)(x - 5) \end{aligned}$$

Factorising $q(x)$, we get,

$$\begin{aligned} q(x) &= x^3 + 27 \\ &= x^3 + (3)^3 \\ &= (x + 3)(x^2 - 3x + 9) \end{aligned}$$

Therefore, GCD of $p(x)$ and $q(x) = x + 3$

But the GCD of $p(x)$ and $q(x)$ is given as $x + k$

Since, GCD of two polynomials is unique.

Therefore, $x + k = x + 3$

$$\Rightarrow k = 3$$

2. Solve for x and y :

$$x + \frac{6}{y} = 6$$

$$3x - \frac{8}{y} = 5$$

OR

Solve for x and y :

$$\frac{x+1}{2} + \frac{y-1}{3} = 8$$

$$\frac{x-1}{3} + \frac{y+1}{2} = 9$$

Ans.

$$x + \frac{6}{y} = 6 \quad (1)$$

$$3x - \frac{8}{y} = 5 \quad (2)$$

From equation (1), we have,

$$x = 6 - \frac{6}{y}$$

Putting this value of x in (2), we get,

$$3\left[6 - \frac{6}{y}\right] - \frac{8}{y} = 5$$

$$\Rightarrow 18 - \frac{18}{y} - \frac{8}{y} = 5$$

$$\Rightarrow 18 - \frac{26}{y} = 5$$

$$\Rightarrow -\frac{26}{y} = 5 - 18$$

$$\Rightarrow -\frac{26}{y} = -13$$

$$\Rightarrow 26 = 13y$$

$$\Rightarrow y = 2$$

$$\text{Therefore, } x = 6 - \frac{6}{y}$$

$$\Rightarrow x = 6 - \frac{6}{2}$$

$$\Rightarrow x = 6 - 3$$

$$\Rightarrow x = 3$$

Thus, the given system of equations has the solution $x = 3$ and $y = 2$.

OR

$$\frac{x+1}{2} + \frac{y-1}{3} = 8 \quad (1)$$

$$\frac{x-1}{3} + \frac{y+1}{2} = 9 \quad (2)$$

Equation (1), can be written as

$$\frac{3x+3+2y-2}{6} = 8$$

$$\Rightarrow 3x + 2y + 1 = 48$$

$$\Rightarrow 3x + 2y = 47 \quad (3)$$

Similarly on simplifying equation (2), we get,

$$\frac{2x-2+3y+3}{6} = 9$$

$$\Rightarrow 2x + 3y + 1 = 54$$

$$\Rightarrow 2x + 3y = 53 \quad (4)$$

Multiplying (3) by (2) and (4) by (3), we get,

$$6x + 4y = 94 \quad (5)$$

$$6x + 9y = 159 \quad (6)$$

Solving (5) and (6)

$$-5y = -65$$

$$\Rightarrow y = 13$$

Substituting $y = 13$ in (3), we get,

$$x = 7$$

3. Find the sum of first 25 terms of an AP whose n^{th} term is $1 - 4n$.

Ans.

$$\text{Given that } T_n = 1 - 4n$$

$$\text{When } n = 1$$

$$T_1 = 1 - 4(1)$$

$$= 1 - 4$$

$$= -3$$

$$T_2 = 1 - 4(2)$$

$$= 1 - 8$$

$$= -7$$

$$\begin{aligned} \text{Common difference } d &= T_2 - T_1 \\ &= -7 - (-3) \\ &= -7 + 3 \\ &= -4 \end{aligned}$$

Sum of n terms is given by

$$S_n = \frac{n}{2}[2a + (n - 1)d]$$

Here $n = 25$, $a = -3$ and $d = -4$

Substituting the values, we get,

$$S_{25} = \frac{25}{2}[2(-3) + (25 - 1)(-4)]$$

$$= \frac{25}{2}[-6 + 24(-4)]$$

$$= \frac{25}{2}[-6 + (-96)]$$

$$= \frac{25}{2}[-102]$$

$$= 25(-51)$$

$$= -1275$$

Hence, the sum of first 25 terms is -1275.

-
4. P and Q are points on sides CA and CB respectively of $\triangle ABC$, right angled at C. Prove that $AQ^2 + BP^2 = AB^2 + PQ^2$

OR

In the figure, $DE \parallel AB$ and $FE \parallel DB$. Prove that $DC^2 = CF \cdot AC$

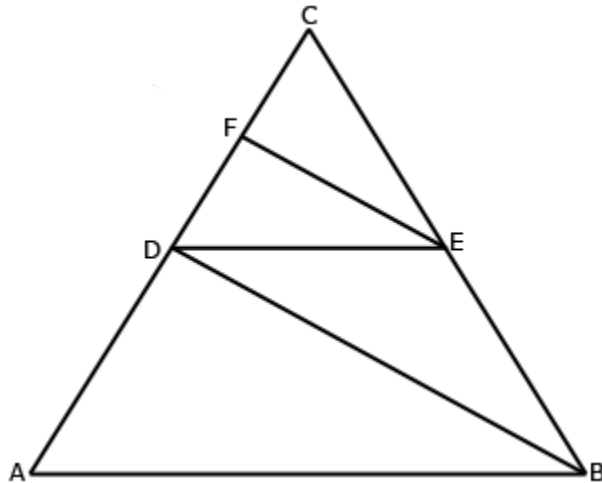

Ans.

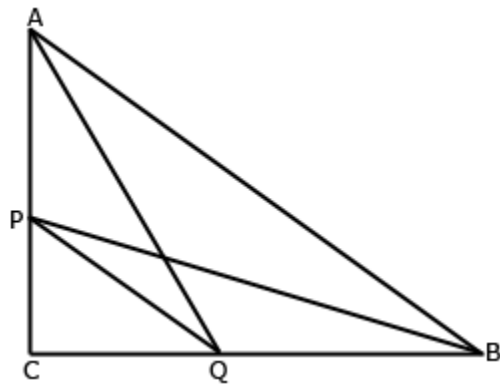

Given: $\triangle ABC$ is right angled triangle at C.
P and Q are points on sides CA and CB respectively.

To Prove: $AQ^2 + BP^2 = AB^2 + PQ^2$

Proof: In $\triangle ACQ$

Using Pythagoras theorem, we have,

$$AQ^2 = AC^2 + CQ^2 \quad (1)$$

Again applying Pythagoras Theorem in $\triangle PCB$

$$BP^2 = PC^2 + BC^2 \quad (2)$$

Adding (1) and (2), we get,

$$AQ^2 + BP^2 = AC^2 + CQ^2 + PC^2 + BC^2$$

$$= (AC^2 + BC^2) + (CQ^2 + PC^2)$$

$$= AB^2 + PQ^2 \quad [\text{using Pythagoras theorem in } \triangle ABC \text{ and } \triangle PQC, \text{ we}]$$

have, $AC^2 + BC^2 = AB^2$ and $CQ^2 + PC^2 = PQ^2$
Hence, proved.

OR

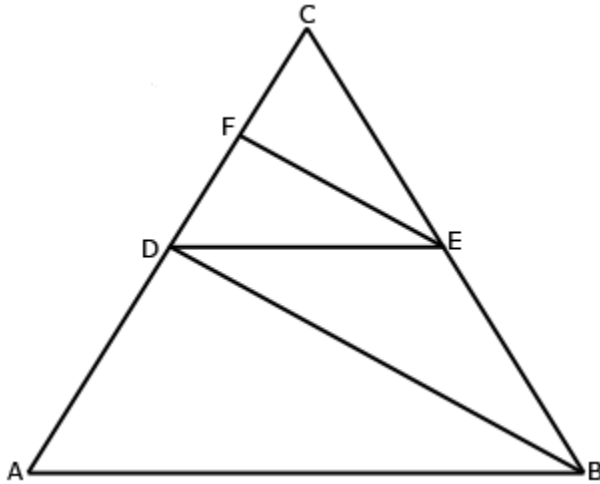

Given: $DE \parallel AB$ and $FE \parallel DB$

To Prove: $DC^2 = CF \cdot AC$

Proof: Since, $DE \parallel AB$

Therefore, $\frac{CD}{AC} = \frac{CE}{CB}$ (1) (By Basic Proportionality Theorem)

Again since, $FE \parallel DB$

Therefore, $\frac{CF}{CD} = \frac{CE}{CB}$ (2) (By Basic Proportionality Theorem)

From (1) and (2), we get,

$$\frac{CD}{AC} = \frac{CF}{CD}$$

$$\Rightarrow CD^2 = CF \cdot AC$$

Hence, proved.

5. The mean of the following frequency distribution is 62.8. Find the missing frequency x .

Class	0 - 20	20 - 40	40 - 60	60 - 80	80 - 100	100 - 120
Frequency	5	8	x	12	7	8

Ans.

Class	Frequency (f_i)	Mid-Point (x_i)	$f_i x_i$
0 - 20	5	10	50
20 - 40	8	30	240
40 - 60	x	50	$50x$
60 - 80	12	70	840
80 - 100	7	90	630
100 - 120	8	110	880
Total	$40 + x$		$2640 + 50x$

Given that $\bar{x} = 62.8$

$$\text{Also, } \bar{x} = \frac{\sum f_i x_i}{\sum f_i}$$

Substituting values, we have,

$$\Rightarrow 62.8 = \frac{2640 + 50x}{40 + x}$$

$$\Rightarrow 2512 + 62.8x = 2640 + 50x$$

$$\Rightarrow 62.8x - 50x = 2640 - 2512$$

$$\Rightarrow 12.8x = 128$$

$$\Rightarrow x = \frac{128 \times 10}{128}$$

$$\Rightarrow x = 10$$

6. Cards marked with number 3, 4, 5, ..., 50 are placed in a box and mixed thoroughly. One card is drawn at random from the box. Find the probability that number of the drawn card is
- Divisible by 7.
 - A number which is a perfect square.

Ans.

We know that probability of an event E , is given by

$$P(E) = \frac{\text{Number of favourable outcomes}}{\text{Total number of outcomes}}$$

Sample space $S = \{3, 4, 5, \dots, 50\}$

(i) Number divisible by 7 = $\{7, 14, 21, 28, 35, 42, 49\}$

$$\text{Therefore, } P(\text{divisible by 7}) = \frac{7}{48}$$

(ii) A number which is perfect square = $\{4, 9, 16, 25, 36, 49\}$

$$\text{Therefore, } P(\text{a number which is perfect square}) = \frac{6}{48} = \frac{1}{8}$$

-
7. A washing machine is available for Rs 13,500 cash or Rs 6,500 as cash down payment followed by three monthly instalments of Rs 2,500 each. Find the rate of interest charged under instalment plan.

Ans.

Cash price of the washing machine = Rs 13,500

Cash down payment = Rs 6,500

Balance due = Rs(13,500 - 6,500) = Rs 7,000

Number of equal instalments = 3

Amount of each instalment = Rs 2,500

Amount paid in instalment = Rs 7,500

Therefore, interest paid in instalment scheme = Rs(7,500 - 7,000)
= Rs 500

Principal for the 1st month = Rs 7,000

Principal for the 2nd month = Rs 4,500

Principal for the 3rd month = Rs 2,000

Total = Rs 13,500

Let the rate of interest be $r\%$ per annum

$$I = \frac{p \times r \times 1}{1200}$$

$$\text{Then, } I = \frac{13,500 \times r \times 1}{100 \times 12}$$

$$\Rightarrow 500 = \frac{13,500 \times r \times 1}{100 \times 12}$$

$$\Rightarrow \frac{500 \times 12}{135} = r$$

$$\Rightarrow r = 44.4\%$$

Section - B

8. Solve the following system of equations graphically:
 $2x + 3y = 8$; $x + 4y = 9$

Ans.

Given system of equations are

$$2x + 3y = 8 \quad (1)$$

$$x + 4y = 9 \quad (2)$$

$$\text{Equation (1)} \Rightarrow x = \frac{8 - 3y}{2}$$

Taking points on line (1)

x	4	1	-2
y	0	2	4

$$\text{Equation (2)} \Rightarrow x = 9 - 4y$$

Taking points on line (2)

x	9	5	1
y	0	1	2

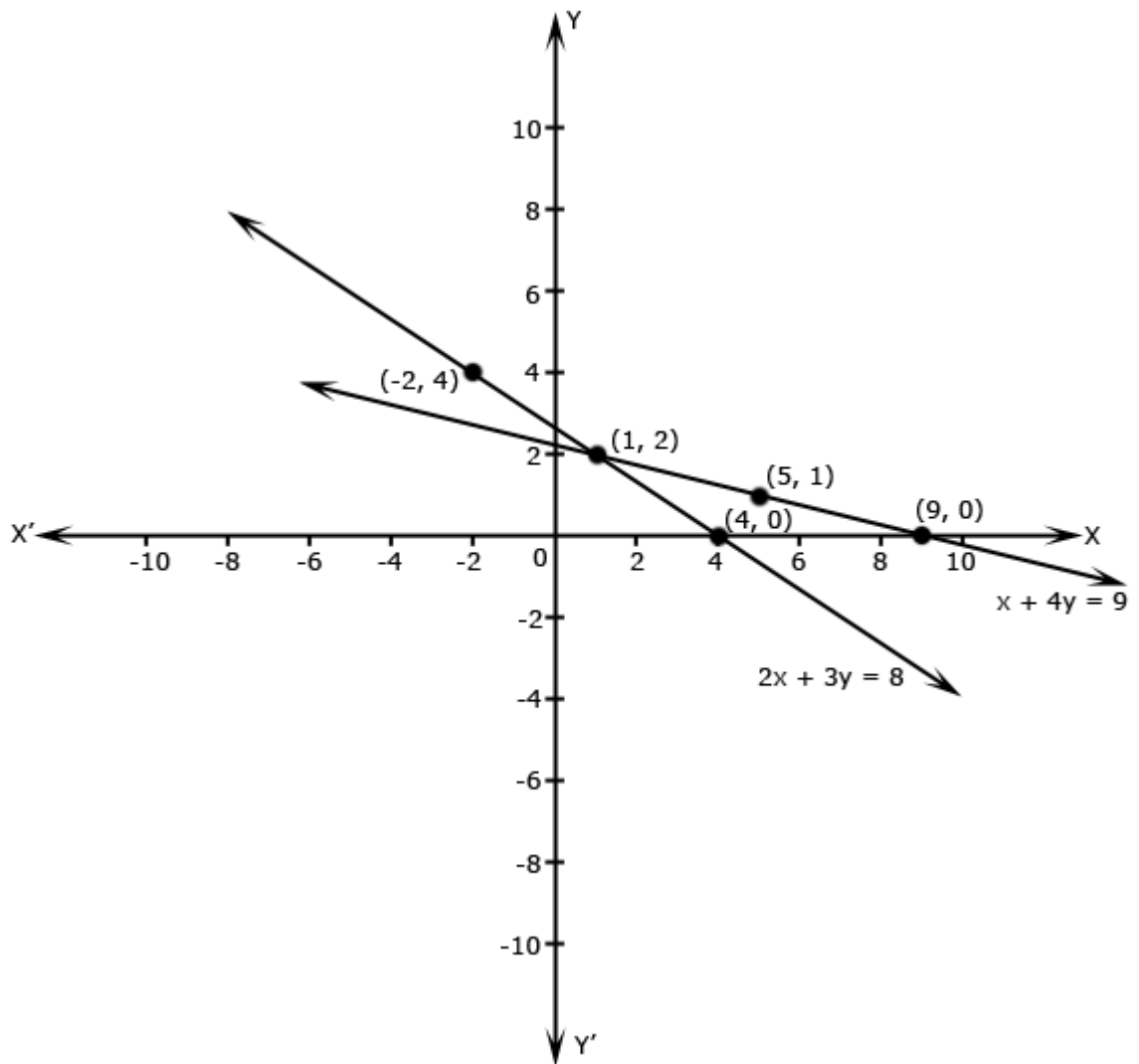

Hence, the solution of the given system of equations is $x = 1, y = 2$.

9. Simplify:

$$\frac{x}{x-y} - \frac{y}{x+y} - \frac{2xy}{x^2 - y^2}$$

Ans.

Consider the given expression

$$\begin{aligned} & \frac{x}{x-y} - \frac{y}{x+y} - \frac{2xy}{x^2 - y^2} \\ &= \frac{x(x+y) - y(x-y)}{(x-y)(x+y)} - \frac{2xy}{x^2 - y^2} \\ &= \frac{x^2 + xy - yx + y^2}{x^2 - y^2} - \frac{2xy}{x^2 - y^2} \\ &= \frac{x^2 + y^2}{x^2 - y^2} - \frac{2xy}{x^2 - y^2} \\ &= \frac{x^2 + y^2 - 2xy}{x^2 - y^2} \\ &= \frac{(x-y)^2}{x^2 - y^2} \quad (\text{Using } a^2 + b^2 - 2ab = (a-b)^2) \\ &= \frac{(x-y)^2}{(x-y)(x+y)} \quad (\text{Using } (a-b)(a+b) = a^2 - b^2) \\ &= \frac{x-y}{x+y} \end{aligned}$$

10. Which term of the AP 3, 15, 27, 39, ... will be 132 more than its 54th term?

Ans.

Given AP is 3, 15, 27, 39, ...

Let a_n be the term of the AP which is 132 more than its 54th term, a_{54} .

So, according to given condition

$$a_n = 132 + a_{54}$$

Here first term $a = 3$

Common difference $d = 15 - 3 = 12$

$$a_n = a + (n-1)d$$

Therefore, $a_{54} = a + (54-1)d$

$$= 3 + 53 \times 12$$

$$= 3 + 636$$

$$= 639$$

Hence, $a_n = 132 + 639$

$$= 771$$

$$\Rightarrow a_n = 771$$

So, $a + (n-1)d = 771$

$$\Rightarrow 3 + (n-1) \times 12 = 771$$

$$\Rightarrow 3 + 12n - 12 = 771$$

$$\Rightarrow -9 + 12n = 771$$

$$\Rightarrow 12n = 771 + 9$$

$$\Rightarrow 12n = 780$$

$$\Rightarrow n = \frac{780}{12}$$

$$\Rightarrow n = 65$$

So, 65th term of the given AP will be 132 more than its 54th term.

- 11.** In the figure, TA is a tangent to the circle from a point T and TBC is a secant to the circle. If AD is the bisector of $\angle CAB$, prove that $\triangle ADT$ is isosceles.

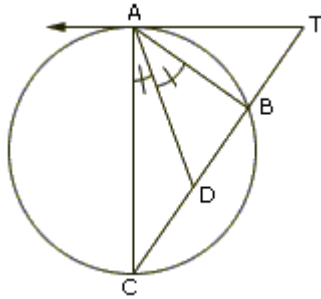

OR

In $\triangle ABC$, $AD \perp BC$ and $AD^2 = BD \cdot DC$. Prove that $\angle BAC$ is a right angle.

Ans.

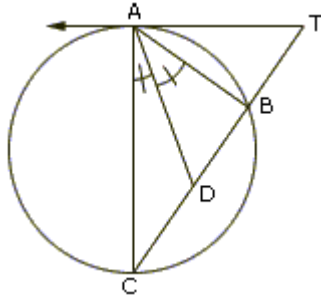

Since, $\angle TAB$ and $\angle BCA$ are angles in the alternate segments of chord AB

$$\Rightarrow \angle TAB = \angle BCA \quad (i)$$

Now, AD is the bisector of $\angle BAC$

$$\text{Therefore, } \angle BAD = \angle CAD \quad (ii)$$

$$\text{Now, } \angle TAD = \angle TAB + \angle BAD$$

$$\Rightarrow \angle TAD = \angle BCA + \angle CAD \quad [\text{using (i) and (ii)}]$$

$$\Rightarrow \angle TAD = \angle DCA + \angle CAD$$

$$\Rightarrow \angle TAD = 180^\circ - \angle CDA$$

$$[\text{since, in } \triangle CAD, \angle CAD + \angle DCA + \angle CDA = 180^\circ]$$

$$\Rightarrow \angle TAD = \angle TDA \quad [\text{since, } \angle CDA + \angle TDA = 180^\circ \text{ by linear pair axiom}]$$

$$\Rightarrow TD = TA \quad (\text{since, sides opposite to equal angles are equal})$$

Hence, $\triangle ADT$ is isosceles

OR

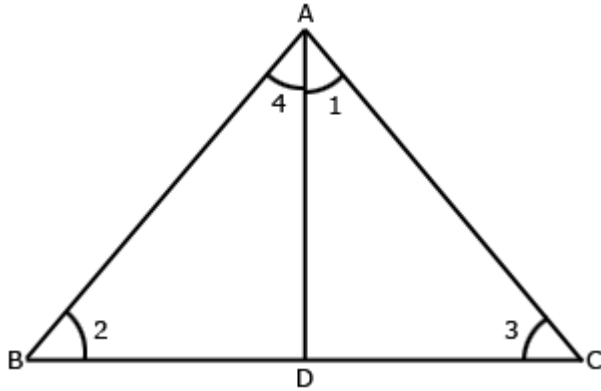

Given: $AD \perp BC$ and $AD^2 = BD \cdot DC$

To prove: $\angle BAC = 90^\circ$

Proof: In $\triangle BDA$ and $\triangle ADC$

$\angle ADB = \angle ADC = 90^\circ$ (Given)

and $\frac{AD}{DC} = \frac{BD}{AD}$ (Given)

Therefore, $\triangle ADC \sim \triangle BDA$ (By SAS similarity rule)

Therefore, $\angle 1 = \angle 2$

and $\angle 1 = \angle 2$ (Angles of similar triangles)

In $\triangle ADC$

$\angle 1 + \angle 3 + \angle ADC = 180^\circ$ (Angle sum property)

$\Rightarrow \angle 1 + \angle 3 + 90^\circ = 180^\circ$ (Given $\angle ADC = 90^\circ$)

$\Rightarrow \angle 1 + \angle 3 = 90^\circ$ (1)

Again in $\triangle ABD$

$\angle 4 + \angle 2 + \angle ADB = 180^\circ$ (Angle sum property)

$\Rightarrow \angle 4 + \angle 2 = 180^\circ - 90^\circ$ (Given $\angle ADB = 90^\circ$)

$= 90^\circ$ (2)

Adding (1) and (2), we get,

$\angle 1 + \angle 3 + \angle 4 + \angle 2 = 180^\circ$

$\angle 1 + \angle 4 + \angle 4 + \angle 1 = 180^\circ$

(Since, $\angle 1 = \angle 2$ and $\angle 3 = \angle 4$)

$\Rightarrow 2\angle 1 + 2\angle 4 = 180^\circ$

$\Rightarrow 2(\angle 1 + \angle 4) = 180^\circ$

$\Rightarrow \angle 1 + \angle 4 = 90^\circ$

$\Rightarrow \angle BAC = 90^\circ$

Hence, proved.

12. Draw a $\triangle PQR$ with base $QR = 6$ cm, vertical angle $P = 60^\circ$ and median through P to the base is of length 4.5 cm.

Ans.

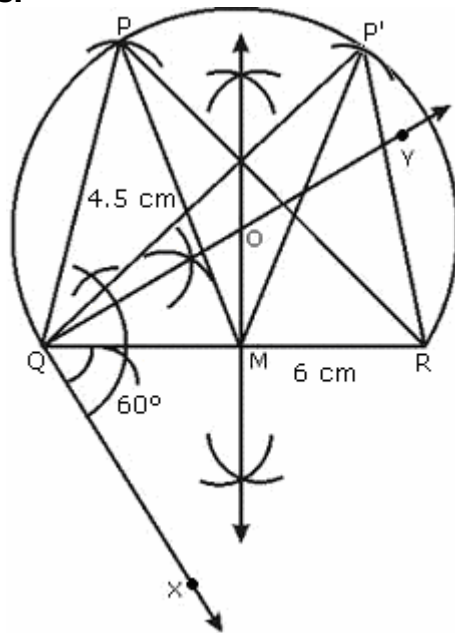

13. A toy is in the form of a cone mounted on a hemisphere of common base radius 7 cm. The total height of the toy is 31 cm. Find the total surface area of the toy. [Use $\pi = \frac{22}{7}$]

Ans.

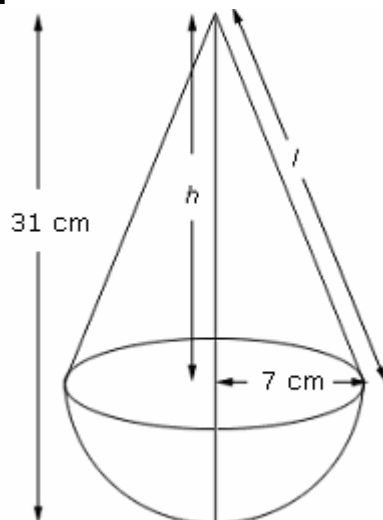

Radius of hemisphere = 7 cm

Therefore, radius of base of the cone = 7 cm

Total height of the toy = 31 cm

Height of the conical part = $(31 - 7)$ cm = 24 cm

Slant height of the conical part, l

$$= \sqrt{h^2 + r^2}$$

$$= \sqrt{24^2 + 7^2}$$

$$= \sqrt{576 + 49}$$

$$= 25 \text{ cm}$$

Therefore, total surface area of the toy

= Surface area of the hemisphere + Surface area of the cone

$$= 2\pi r^2 + \pi r l$$

$$= 2 \times \frac{22}{7} \times 7 \times 7 + \frac{22}{7} \times 7 \times 25$$

$$= 22 \times (14 + 25)$$

$$= 22 \times 39$$

$$= 858$$

Therefore, the total surface area of the toy is 858cm^2

14. The enrolment of a secondary school in different classes is given below:

Class	VI	VII	VIII	IX	X
Enrolment	600	500	400	700	200

Draw a pie chart to represent the above data.

Ans.

Class	Interval	Share as a component of 360°
VI	600	$\frac{600}{2400} \times 360^\circ = 90^\circ$
VII	500	$\frac{500}{2400} \times 360^\circ = 75^\circ$
VIII	400	$\frac{400}{2400} \times 360^\circ = 60^\circ$
IX	700	$\frac{700}{2400} \times 360^\circ = 105^\circ$
X	200	$\frac{200}{2400} \times 360^\circ = 30^\circ$
Total	2400	360°

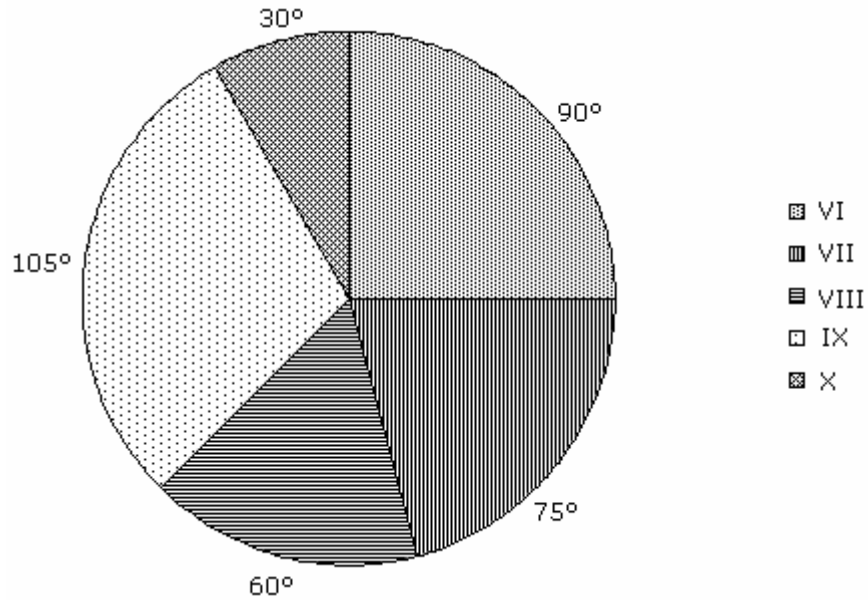

15. A bag contains 5 red balls and some blue balls. If the probability of drawing a blue ball from the bag is thrice that of a red ball, find the number of blue balls in the bag.

Ans.

Red balls = 5

Let the number of blue balls be x .

So, total balls = $5 + x$

We know that probability of an event E is given by

$$P(E) = \frac{\text{Number of favourable outcomes}}{\text{Total number of outcomes}}$$

$$\text{Therefore, } P(\text{blue ball}) = \frac{x}{5 + x}$$

$$P(\text{Red ball}) = \frac{5}{5 + x}$$

According to the given condition

$$\frac{x}{5 + x} = 3 \left(\frac{5}{5 + x} \right)$$

$$\Rightarrow x = 15$$

Hence, the number of blue balls are 15.

16. Prove that

$$\frac{\cos A}{1 - \tan A} + \frac{\sin A}{1 - \cot A} = \sin A + \cos A$$

OR

Evaluate without using trigonometric tables:

$$\frac{3 \cos 55^\circ}{7 \sin 35^\circ} - \frac{4(\cos 70^\circ \cdot \operatorname{cosec} 20^\circ)}{7(\tan 5^\circ \cdot \tan 25^\circ \cdot \tan 45^\circ \cdot \tan 65^\circ \cdot \tan 85^\circ)}$$

Ans.

Given identity is

$$\frac{\cos A}{1 - \tan A} + \frac{\sin A}{1 - \cot A} = \sin A + \cos A$$

$$\text{Consider LHS} = \frac{\cos A}{1 - \tan A} + \frac{\sin A}{1 - \cot A}$$

$$= \frac{\cos^2 A}{\cos A - \sin A} + \frac{\sin^2 A}{\sin A - \cos A} \quad \left(\text{Using } \tan A = \frac{\sin A}{\cos A}, \cot A = \frac{\cos A}{\sin A} \right)$$

$$\Rightarrow \frac{\cos^2 A - \sin^2 A}{\cos A - \sin A} = \frac{(\cos A - \sin A)(\cos A + \sin A)}{\cos A - \sin A}$$

$$= \cos A + \sin A$$

$$= \text{RHS}$$

OR

Consider the expression

$$\begin{aligned} & \frac{3 \cos 55^\circ}{7 \sin 35^\circ} - \frac{4(\cos 70^\circ \cdot \operatorname{cosec} 20^\circ)}{7(\tan 5^\circ \cdot \tan 25^\circ \cdot \tan 45^\circ \cdot \tan 65^\circ \cdot \tan 85^\circ)} \\ &= \frac{3 \cos(90^\circ - 35^\circ)}{7 \sin 35^\circ} - \frac{4(\cos 70^\circ \cdot \operatorname{cosec}(90^\circ - 70^\circ))}{7 \tan 5^\circ \cdot \tan 25^\circ \cdot 1 \cdot \tan(90^\circ - 25^\circ) \tan(90^\circ - 85^\circ)} \\ &= \frac{3 \sin 35^\circ}{7 \sin 35^\circ} - \frac{4(\cos 70^\circ \cdot \sec 70^\circ)}{7(\tan 5^\circ \cdot \cot 5^\circ \cdot \tan 25^\circ \cdot 1 \cdot \cot 25^\circ)} \end{aligned}$$

[Using $\cos(90^\circ - \theta) = \sin \theta$, $\operatorname{cosec}(90^\circ - \theta) = \sec \theta$, $\tan(90^\circ - \theta) = \cot \theta$]

$$= \frac{3}{7} - \frac{4}{7}$$

$$= -\frac{1}{7}$$

17.Show that the points (7, 10), (-2, 5) and (3, -4) are the vertices of an isosceles right triangle.

Ans.

Let the points A(-2, 5), B(3, -4) and C(7, 10) be the vertices of $\triangle ABC$

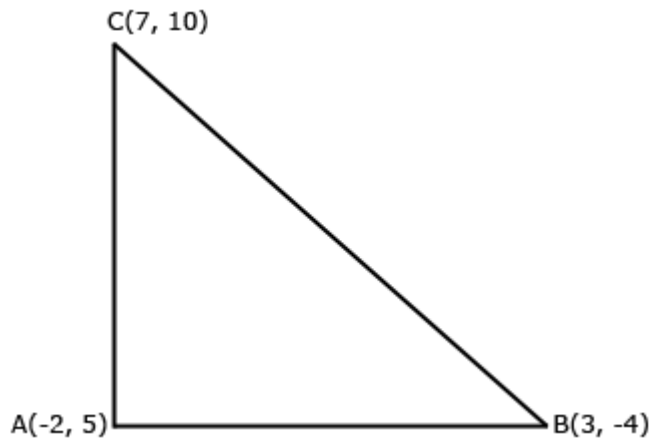

Using distance formula

$$AB^2 = (3 + 2)^2 + (-4 - 5)^2 = 25 + 81 = 106$$

$$BC^2 = (7 - 3)^2 + (10 + 4)^2 = 212$$

$$AC^2 = (7 + 2)^2 + (10 - 5)^2 = 106$$

$$\text{We see that } BC^2 = AB^2 + AC^2$$

$$\Rightarrow \angle A = 90^\circ \quad (\text{Using Pythagoras Theorem})$$

$$\text{Also, } AB = AC$$

Thus, $\triangle ABC$ is an isosceles right triangle.

18.In what ratio does the line $x - y - 2 = 0$ divides the line segment joining (3, -1) and (8, 9)?

Ans.

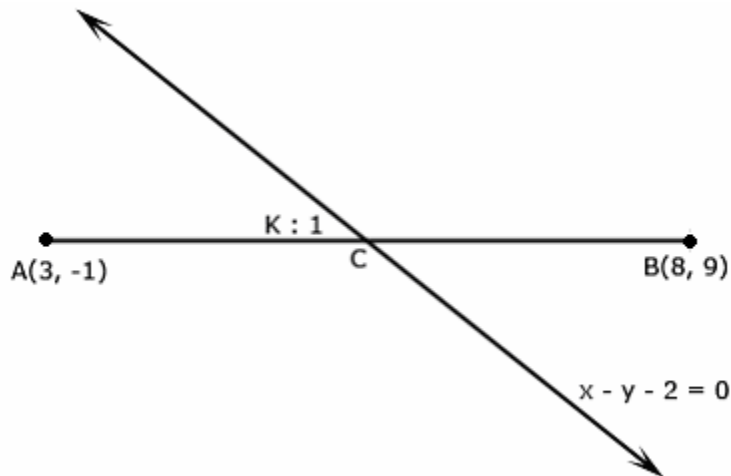

Let the line $x - y - 2 = 0$ divides the line segment joining A(3, -1) and B(8, 9)

in the ratio $k : 1$.

Let the point of intersection be $C(x, y)$

Therefore, $x = \frac{8k+3}{k+1}$ and $y = \frac{9k-1}{k+1}$ (By using section formula)

But (x, y) lies on line $x - y - 2 = 0$

$$\text{So, } \frac{8k+3}{k+1} - \left(\frac{9k-1}{k+1} \right) - 2 = 0$$

$$\Rightarrow 8k + 3 - 9k + 1 - 2k - 2 = 0$$

$$\Rightarrow -3k + 2 = 0$$

$$\Rightarrow 3k = 2$$

$$\Rightarrow k = \frac{2}{3}$$

Therefore, line $x - y - 2 = 0$ divides the line segment joining $(3, -1)$ and $(8, 9)$ in the ratio $2 : 3$.

- 19.** A man borrows money from a finance company and has to pay it back in two equal half-yearly instalments of Rs 7,396 each. If the interest is charged by the finance company at the rate of 15% per annum, compounded semi-annually, find the principal and the total interest paid.

Ans.

Amount of the instalment = Rs 7,396

Therefore, rate = $\frac{15}{2}$ % half yearly

Principal for the 1st instalment will be

$$\text{Therefore, } P_1 = 7396 \div \left(1 + \frac{15}{200} \right)$$

$$= 7396 \div \left(\frac{215}{200} \right)$$

$$= 7396 \times \frac{200}{215}$$

$$= \text{Rs } 6,880$$

Principal for the II instalment will be

$$P_2 = 7396 \div \left(1 + \frac{15}{200} \right)^2$$

$$= 7396 \times \frac{200}{215} \times \frac{200}{215}$$

$$= \text{Rs } 6,400$$

Therefore, principal = $P_1 + P_2$

$$= \text{Rs } 6,880 + 6,400$$

$$= \text{Rs } 13,280$$

Total interest paid = $\text{Rs } 7,396 \times 2 - 13,280$

$$= \text{Rs } 1,512$$

SECTION – C

20. If a line is drawn parallel to one side of a triangle, to intersect the other two sides in distinct points, prove that the other two sides are divided in the same ratio.

Using the above, prove the following:

In the figure, $DE \parallel BC$ and $BD = CE$. Prove that ABC is an isosceles triangle.

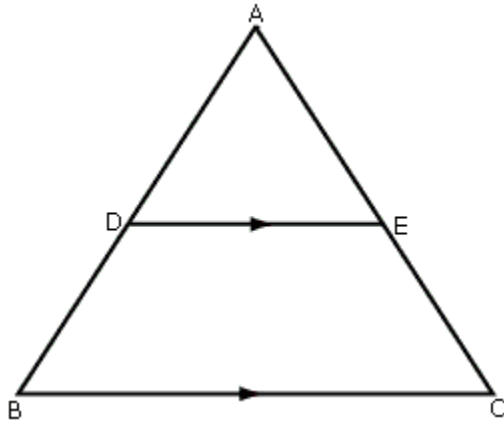

Ans.

Given: $\triangle ABC$ in which $DE \parallel BC$

To prove: $\frac{AD}{DB} = \frac{AE}{EC}$

Construction: Join BE, CD and draw $EP \perp AB$

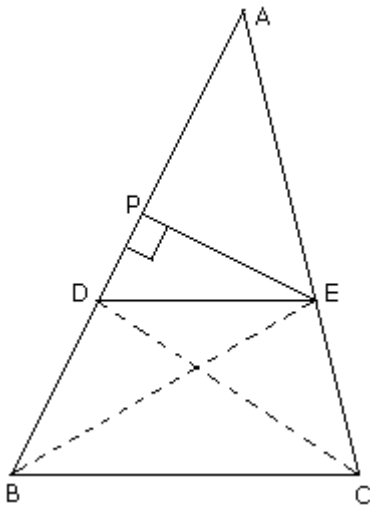

Proof:

$\triangle DEB$ and $\triangle DEC$ are on the same base DE and between the same parallels DE and BC

Therefore, $\text{area } \triangle DEB = \text{area } \triangle DEC$ (i)

$$\frac{\text{area } \triangle ADE}{\text{area } \triangle DEB} = \frac{\frac{1}{2}AD \times EP}{\frac{1}{2}BD \times EP} \quad (\text{Area of } \triangle = \frac{1}{2} \text{Base} \times \text{Height})$$

$$= \frac{AD}{BD} \quad (\text{ii})$$

$$\text{Similarly, } \frac{\text{area } \triangle ADE}{\text{area } \triangle DEC} = \frac{AE}{EC}$$

$$\text{or } \frac{\text{area } \triangle ADE}{\text{area } \triangle DEB} = \frac{AE}{EC} \quad (\text{iii}) \quad [\text{From (i)}]$$

Using (ii) and (iii), we get

$$\frac{AD}{DB} = \frac{AE}{EC}$$

Part II:

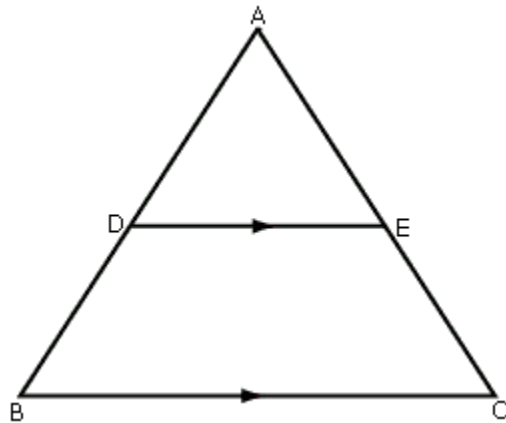

Given: $DE \parallel BC$ and $BD = CE$

To prove: $\triangle ABC$ is an isosceles triangle.

Proof: Since, $DE \parallel BC$

Therefore, $\frac{AD}{DB} = \frac{AE}{EC}$ (By above theorem)

$$\frac{AD}{DB} + 1 = \frac{AE}{EC} + 1$$

$$\Rightarrow \frac{AD + DB}{DB} = \frac{AE + EC}{EC}$$

$$\Rightarrow \frac{AB}{DB} = \frac{AC}{EC}$$

$$\Rightarrow AB = AC \quad (\text{As } BD = CE \text{ (given)})$$

$\Rightarrow \triangle ABC$ is an isosceles triangle.

21. Prove that the sum of either pair of opposite angles of a cyclic quadrilateral is 180° . Using the above, find x and y in the figure.

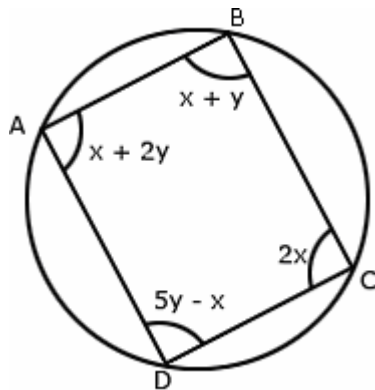

Ans.

Given: A cyclic quadrilateral PQRS and circle $C(O, r)$

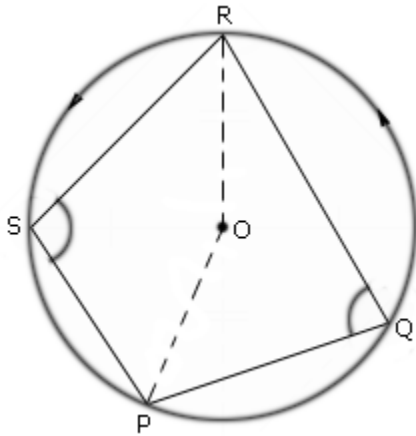

To prove: $\angle P + \angle R = 180^\circ$
 $\angle S + \angle Q = 180^\circ$

Construction: Join OP and OR

Proof: Since, arc PR subtends $\angle PSR$ in its alternate segment,

$$\Rightarrow \angle PSR = \frac{1}{2} \angle POR \quad (\text{i})$$

Also, arc RP subtends $\angle PQR$ in its alternate segment, therefore,

$$\Rightarrow \angle PQR = \frac{1}{2} \angle ROP \quad (\text{ii})$$

Adding (i) and (ii), we get,

$$\angle PSR + \angle PQR = \frac{1}{2} (\angle POR + \angle ROP)$$

$$= \frac{1}{2} \times 360^\circ$$

$$= 180^\circ$$

$$\Rightarrow \angle S + \angle Q = 180^\circ$$

Now, in quadrilateral PQRS, we have,

$$\angle P + \angle Q + \angle R + \angle S = 360^\circ \quad (\text{angle sum property of a quadrilateral})$$

$$\Rightarrow \angle P + \angle R + 180^\circ = 360^\circ$$

$$\Rightarrow \angle P + \angle R = 360^\circ - 180^\circ$$

$$\Rightarrow \angle P + \angle R = 180^\circ$$

$$\text{Hence, } \angle P + \angle R = 180^\circ$$

$$\text{and } \angle S + \angle Q = 360^\circ$$

Hence, proved

Part II:

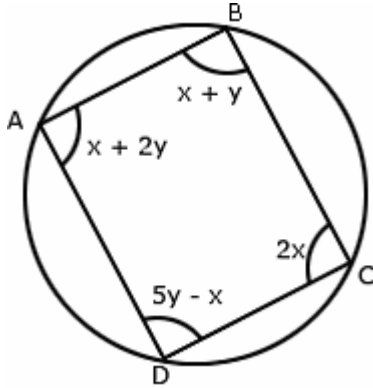

$$\text{Here } x + y + 5y - x = 180^\circ \quad (\text{Using above Theorem})$$

$$\Rightarrow 6y = 180^\circ$$

$$\Rightarrow y = 30^\circ$$

$$\text{Again } x + 2y + 2x = 180^\circ \quad (\text{Using above Theorem})$$

$$\Rightarrow 3x + 2y = 180^\circ$$

$$\Rightarrow 3x + 2(30^\circ) = 180^\circ$$

$$\Rightarrow 3x + 60^\circ = 180^\circ$$

$$\Rightarrow 3x = 120^\circ$$

$$\Rightarrow x = 40^\circ$$

Hence, $x = 40^\circ$ and $y = 30^\circ$.

22. The difference of two numbers is 5 and the difference of their reciprocals is $\frac{1}{10}$. Find the numbers.

OR

By increasing the list price of a book by Rs 10 a person can buy 10 less books for Rs 1,200. Find the original list price of the book.

Ans.

Let one number be x
and other number be y
According to the given condition
 $x - y = 5$ (1)

$$\text{and } \frac{1}{y} - \frac{1}{x} = \frac{1}{10}$$

$$\Rightarrow \frac{x - y}{xy} = \frac{1}{10}$$

$$\Rightarrow \frac{5}{xy} = \frac{1}{10} \quad (\text{Using (1)})$$

$$\Rightarrow \frac{1}{xy} = \frac{1}{50}$$

$$\Rightarrow xy = 50$$

$$\Rightarrow y(y + 5) = 50 \quad (\text{Using (1)})$$

$$\Rightarrow y^2 + 5y - 50 = 0$$

$$\Rightarrow y^2 + 10y - 5y - 50 = 0$$

$$\Rightarrow y(y + 10) - 5(y + 10) = 0$$

$$\Rightarrow (y - 5)(y + 10) = 0$$

$$\Rightarrow y = 5 \text{ or } y = -10$$

$$\text{If } y = 5, \text{ then } x = 5 + y = 10$$

$$\text{If } y = -10 \text{ then } x = 5 + y = 5 - 10 = -5$$

Hence, the two numbers are 10 and 5 or -5 and -10.

OR

Let the original price of books be Rs x .

and let the number of books be Rs y

Then according to given condition

$$xy = 1,200 \quad (1)$$

$$\text{and } (x + 10)(y - 10) = 1200$$

$$\Rightarrow xy - 10x + 10y - 100 = 1200$$

$$\Rightarrow xy - 10x + 10y = 1300 \quad (2)$$

$$\Rightarrow 1200 - 10x + 10y = 1300 \quad (\text{Using (1)})$$

$$\Rightarrow -10x + 10y = 100$$

$$\Rightarrow y - x = 10$$

$$\Rightarrow \frac{1200}{x} - x = 10 \quad [\text{Using (1)}]$$

$$\Rightarrow 1200 - x^2 = 10x$$

$$\Rightarrow x^2 + 10x - 1200 = 0$$

$$\Rightarrow x^2 + 40x - 30x - 1200 = 0$$

$$\Rightarrow x(x + 40) - 30(x + 40) = 0$$

$$\Rightarrow (x - 30)(x + 40) = 0$$

$$\Rightarrow x = 30 \text{ or } x = -40$$

Reject $x = -40$ as price cannot be negative.

Therefore, $x = 30$

Hence, the original price of book is Rs 30.

-
23. A sphere, of diameter 12 cm, is dropped in a right circular cylindrical vessel, partly filled with water. If the sphere is completely submerged in water, the water level in the cylindrical vessel rises by $3\frac{5}{9}$ cm. Find the diameter of the cylindrical vessel.

OR

A solid right circular cone of diameter 14 cm and height 8 cm is melted to form a hollow sphere. If the external diameter of the sphere is 10 cm, find the internal diameter of the sphere.

Ans.

$$\text{Volume of sphere} = \frac{4}{3}\pi r^3$$

Diameter = 12 cm

Therefore, radius = 6 cm

$$\text{Volume of sphere} = \frac{4}{3} \times \pi \times 6 \times 6 \times 6 \quad (1)$$

Let R be radius of cylinder, h be level of water initially and H be the final level

$$\text{rise in water level} = H - h = \frac{32}{9}$$

Increase in volume of the water in cylinder = $\pi R^2(H - h)$

$$= \pi \times R \times R \times \frac{32}{9} \quad (2)$$

Increase in volume of water = Volume of sphere

From (1) and (2), we get,

$$\frac{4}{3} \times \pi \times 6 \times 6 \times 6 = \pi \times R^2 \times \frac{32}{9}$$

$$\Rightarrow \frac{4 \times 2 \times 6 \times 6 \times 9}{32} = R^2$$

$$\Rightarrow R^2 = 3 \times 3 \times 3 \times 3$$

$$\Rightarrow R = \sqrt{3 \times 3 \times 3 \times 3}$$

$$\Rightarrow R = 9 \text{ cm}$$

$$\begin{aligned} \text{Therefore, diameter of cylindrical vessel} &= 2R \\ &= 2(9) = 18 \text{ cm} \end{aligned}$$

OR

Diameter of cone = 14 cm

Therefore, radius = 7 cm

$h = 8$ cm

$$\text{Volume of cone} = \frac{1}{3} \pi r^2 h$$

$$= \frac{1}{3} \times \pi \times 7 \times 7 \times 8$$

External diameter of sphere = 10 cm

Therefore, external radius of sphere $r_1 = 5$ cm

Let the internal radius of sphere be r_2 .

According to the question

Volume of cone = Volume of hollow sphere

$$\Rightarrow \frac{1}{3} \pi r^2 h = \frac{4}{3} \pi (r_1^3 - r_2^3)$$

$$\Rightarrow \frac{1}{3} \pi \times 7 \times 7 \times 8 = \frac{4}{3} \pi (125 - r_2^3)$$

$$\Rightarrow 7 \times 7 \times 2 = (125 - r_2^3)$$

$$\Rightarrow 98 - 125 = -r_2^3$$

$$\Rightarrow -27 = -r_2^3$$

$$\Rightarrow r_2 = 3 \text{ cm}$$

Hence, the internal radius of the sphere is 3 cm.

Therefore, the internal diameter of the sphere = $3(2)$
= 6 cm

- 24.** A boy standing on a horizontal plane finds a bird flying at a distance of 100 m from him at an elevation of 30° . A girl standing on the roof of 20 m high building, finds the angle of elevation of the same bird to be 45° . Both the boy and the girl are on opposite sides of a bird. Find the distance of bird from the girl.

Ans.

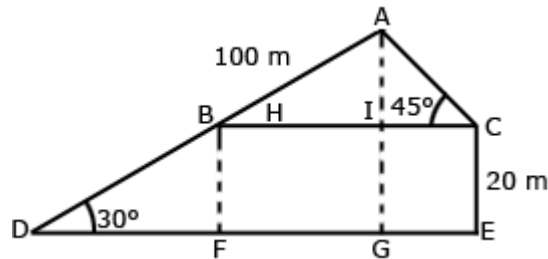

Let the boy is standing at the point D and bird is at point A and $CE = 20$ m be the building and girl is standing at the point C.

$AD = 100$ m

AC is distance of bird from the girl.

In $\triangle AIC$

$$\frac{AI}{AC} = \sin 45^\circ$$

$$\Rightarrow AI = AC \times \frac{1}{\sqrt{2}}$$

$$\Rightarrow AC = \sqrt{2} AI \quad (1)$$

In $\triangle ADG$

$$\sin 30^\circ = \frac{AG}{AD}$$

$$\Rightarrow \frac{1}{2} = \frac{AG}{100}$$

$$\Rightarrow AG = \frac{100}{2} = 50 \text{ m}$$

$$\begin{aligned} AI &= AG - IG \\ &= 50 - 20 \quad (\text{Since, CE} = IG = 20 \text{ m}) \\ &= 30 \text{ m} \end{aligned}$$

$$\text{Therefore, AC} = \sqrt{2} \times 30 \quad (\text{Using (1)})$$

$$\text{Therefore, AC} = 42.426 \sim 42.43 \text{ m}$$

25. Ms. Shahnaz earns Rs 35,000 per month (excluding HRA). She donates Rs 30,000 to Prime Minister Relief Fund (100% exemption) and Rs 40,000 to a Charitable Hospital (50% exemption). She contributes Rs 5,000 per month to Provident Fund and Rs 25,000 per annum towards LIC premium. She purchases NSC worth Rs 20,000. She pays Rs 2,300 per month towards income tax for 11 month. Find the amount of income tax she has to pay in 12th month of the year.

Use the following to calculate income tax:

(a) **Savings:** 100% exemption for permissible saving upto Rs 1,00,000

(b) **Rates of income tax for ladies**

Slab	Income Tax
(i) Upto Rs 1,35,000	No Tax
(ii) From Rs 1,35,001 to Rs 1,50,000	10% of taxable income exceeding Rs 1,35,000
(iii) From Rs 1,50,001 to Rs 2,50,000	Rs 1,500 + 20% of the amount exceeding Rs 1,50,000
(iv) Rs 2,50,001 and above	Rs 21,500 + 30% of the amount exceeding Rs 2,50,000

(c) **Education Cess:** 2% of income tax payable

Ans.

$$\begin{aligned} \text{Gross income of Ms. Shahnaz} &= \text{Rs } 35,000 \times 12 \\ &= \text{Rs } 4,20,000 \end{aligned}$$

Donations:

$$\text{Donation to Prime Minister Relief Fund} = \text{Rs } 30,000$$

$$\text{Donation to Charitable Hospital} = \text{Rs } 40,000$$

$$\text{Exemption} = \text{Rs } 30,000(100\%)$$

$$= \text{Rs } 20,000(50\%)$$

$$\text{Exemption} = \text{Rs } 50,000$$

Savings:

$$\text{PF} = 5,000 \times 12 = \text{Rs } 60,000$$

$$\text{LIC} = \text{Rs } 25,000$$

NSC = Rs 20,000

Total savings = Rs 1,05,000

But saving is subject to maximum of Rs 1,00,000

Therefore, taxable income = Rs(4,20,000 - 50,000 - 1,00,000)
= Rs(4,20,000 - 1,50,000)
= Rs 2,70,000

Income tax = $21,500 + \frac{30}{100}(2,70,000 - 2,50,000)$
= $21,500 + \frac{30}{100}(20,000)$
= Rs 21,500 + 6,000
= Rs 27,500

Education Cess = $\frac{2}{100} \times 27,500$
= Rs 550

Total tax to be paid = Rs(27,500 + 550)
= Rs 28,050

Income tax paid for 11 months = Rs 2,300 × 11
= Rs 25,300

Therefore, income tax to be paid in 12th month of year = Rs(28,050 - 25,300)
= Rs 2,750